



# Unsteady 3D Flow Past a Cylinder

## Introduction

---

Fluid flow past a cylinder is a common test case in computational fluid dynamics. The flow pattern is characterized by the Reynolds number which is defined as

$$\text{Re} = \frac{\rho U_{\text{mean}} D}{\mu}$$

where  $\rho$  is the density,  $U_{\text{mean}}$  is the mean velocity of the free stream,  $D$  is the cylinder diameter, and  $\mu$  is the dynamic viscosity.

The flow patterns around a cylinder in a free stream for different Reynolds numbers are shown in [Ref. 1](#). At  $\text{Re}$  below 5, the flow remains attached to the cylinder. For  $\text{Re}$  between 5 and 15, steady wake vortices start forming on the downstream side of the cylinder. The wake becomes unsteady and forms a laminar vortex street for  $\text{Re}$  between 40 and 150.

Flow around a cylinder in a channel is even more complicated due to the effect of wall boundaries. Computer simulations of this problem at the intermediate  $\text{Re}$  regime (between 40 and 150) are challenging since they need to be 3D and time-dependent.

In this verification model, a benchmark problem of unsteady, incompressible 3D flow past a cylinder for  $\text{Re} = 100$  during a period of 8 seconds is considered. The lift and drag coefficients are computed and are compared with those in [Ref. 2](#).

## Model Definition

---

The geometry is a cylinder of radius  $R$  with the axis parallel to the  $z$ -axis, and placed at  $(x_c, y_c, 0)$ , inside the box  $[0, L] \times [0, H] \times [0, H]$ . [Figure 1](#) shows the geometry corresponding to  $R = 0.05$  m,  $L = 2.5$  m,  $H = 0.5$  m, and  $x_c = 0.5$  m,  $y_c = 0.2$  m.

The fluid to be considered is incompressible and Newtonian with a kinematic viscosity of  $10^{-3}$  m<sup>2</sup>/s. The inflow velocity profile varies in time according to

$$U(0, y, z, t) = 36 U_{\text{mean}} yz \frac{(H-y)(H-z)}{H^4} \sin\left(\frac{\pi t}{8}\right), V=W=0.$$

The lift and drag coefficients  $C_D$  and  $C_L$  are computed as functions of time,

$$C_D(t) = \frac{2F_D(t)}{\rho U_{\text{mean}}^2 A}, \quad C_L(t) = \frac{2F_L(t)}{\rho U_{\text{mean}}^2 A}$$

where  $F_D$  and  $F_L$  are the drag and lift forces, and  $A$  is the projected area,  $A = 2RH$ .

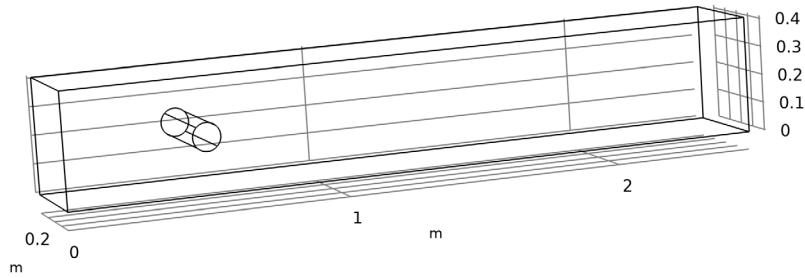

*Figure 1: The geometry is a cylinder placed inside a box.*

The simulation is performed with a relatively coarse mesh with 7200 hexahedral elements shown in [Figure 2](#). P2+P2 shape functions are chosen for the velocity and pressure to allow for better conservation and higher accuracy compared to P2+P1 and P1+P1. The generalized alpha method with automatic time stepping is chosen since it has less damping than the BDF method.

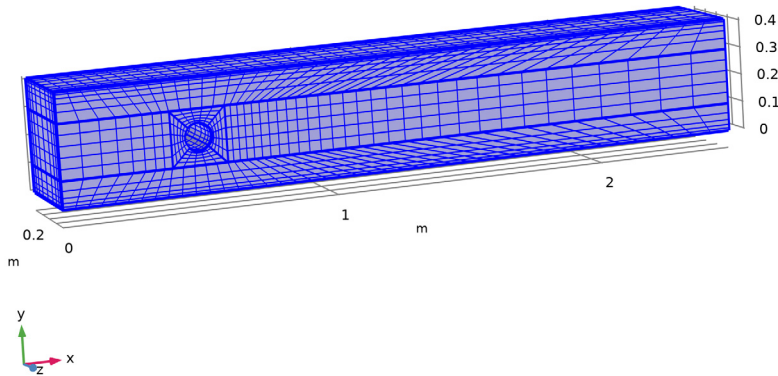

*Figure 2: The relatively coarse mesh, with 7200 hexahedral elements, used in the simulation.*

## Results and Discussion

Figure 3 shows the flow pattern at  $t = 7.95$  s, the last saved time before the inflow velocity returns to zero.

The lift and drag coefficients versus time are shown in Figure 4 and Figure 5 respectively. They capture the general shape of those published Ref. 1 quite well. Note that the nonzero drag at  $t = 0$  s is due to the initial acceleration at the inlet boundary.

In order to verify the results, the L2 norm is computed for the lift and drag coefficients over the entire solved time-span. The results are consistent with those published Ref. 2. The relative error in lift is around 12% and the relative error in drag is approximately 1.2%.

When the mesh size is reduced by a factor of 2, resulting in 57,600 elements, the computational time increases by a factor of 8 but the agreement with the current simulation is still excellent.

Time=7.95 s    Slice: Velocity magnitude (m/s)    Streamline: Velocity field    Surface: 1 (1)

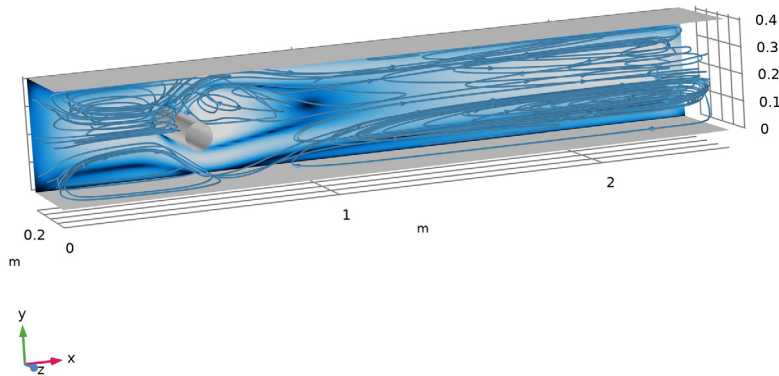

Figure 3: Computed velocity field at  $t = 7.95$  s.

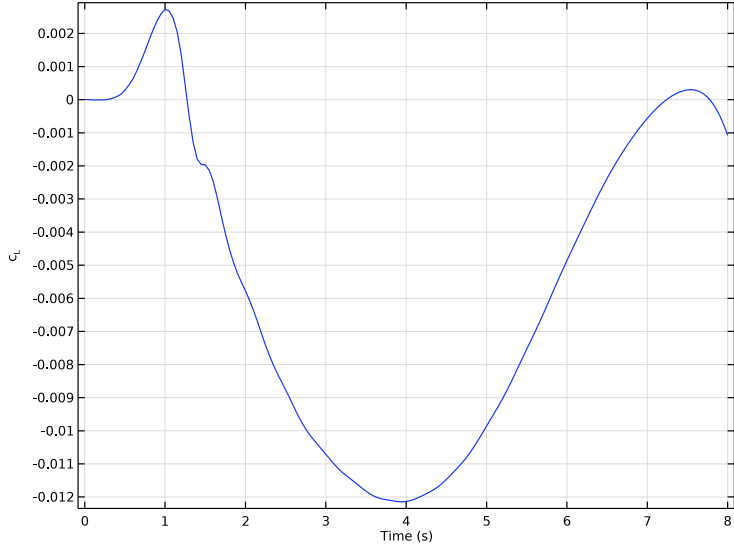

Figure 4: Lift coefficient versus time.

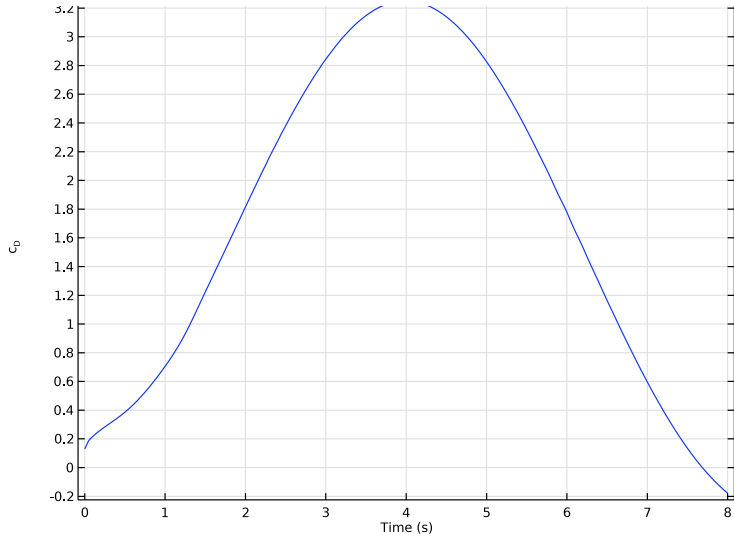

Figure 5: Drag coefficient versus time.

## Notes About the COMSOL Implementation

---

The space discretization P2+P2 coupled with the generalized alpha time discretization works efficiently for this application. P2+P2 elements allow for a coarser mesh, better conservation, and more accuracy compared to P2+P1 and P1+P1 elements. The generalized alpha method has less damping than the BDF method. Automatic time-stepping works well and relatively large time steps can be used, and thus less computational time is needed compared to [Ref. 2](#).

## References

---

1. M. Van Dyke, *An album of fluid motion*, the Parabolic Press, ISBN 0-915760-03-7, 1982.
2. E. Bayraktar, O. Mierka, and S. Turek, “Benchmark Computation of 3D Laminar Flow Around a Cylinder with CFX, OpenFOAM and FeatFlow,” *IJCSE*, vol. 7, no. 3, pp. 253–266, 2012.

---

**Application Library path:** CFD\_Module/Verification\_Examples/  
cylinder\_flow\_3d\_periodic

---

## Modeling Instructions



---

From the **File** menu, choose **New**.

### NEW

In the **New** window, click  **Model Wizard**.

### MODEL WIZARD

- 1 In the **Model Wizard** window, click  **3D**.
- 2 In the **Select Physics** tree, select **Fluid Flow** > **Single-Phase Flow** > **Laminar Flow (spf)**.
- 3 Click **Add**.
- 4 Click  **Study**.
- 5 In the **Select Study** tree, select **General Studies** > **Time Dependent**.
- 6 Click  **Done**.

## GLOBAL DEFINITIONS

### Parameters 1

- 1 In the **Model Builder** window, under **Global Definitions** click **Parameters 1**.
- 2 In the **Settings** window for **Parameters**, locate the **Parameters** section.
- 3 In the table, enter the following settings:

Name	Expression	Value	Description
U_mean	1[m/s]	1 m/s	Mean inflow velocity
rho	1[kg/m^3]	1 kg/m <sup>3</sup>	Density
mu	0.001[Pa*s]	0.001 Pa*s	Dynamic viscosity
H	0.41[m]	0.41 m	Height and Width
L	2.5[m]	2.5 m	Length
xc	0.5[m]	0.5 m	Cylinder x-pos
yc	0.2[m]	0.2 m	Cylinder y-pos
R	0.05[m]	0.05 m	Cylinder radius
dt	0.05	0.05	
N	160	160	
final	N*dt	8	

## GEOMETRY 1

First, create the box  $[0, L] \times [0, H] \times [0, H]$ .

### Block 1 (blk1)

- 1 In the **Geometry** toolbar, click  **Block**.
- 2 In the **Settings** window for **Block**, locate the **Size and Shape** section.
- 3 In the **Width** text field, type L.
- 4 In the **Depth** text field, type H.
- 5 In the **Height** text field, type H.

Next, create a smaller box around the cylinder. This box will be used later on in the meshing sequence.



### Block 2 (blk2)

- 1 In the **Geometry** toolbar, click  **Block**.
- 2 In the **Settings** window for **Block**, locate the **Size and Shape** section.
- 3 In the **Width** text field, type  $4 * R$ .

- 4 In the **Depth** text field, type  $4 \cdot R$ .
- 5 In the **Height** text field, type  $H$ .
- 6 Locate the **Position** section. In the **x** text field, type  $x_c - 2 \cdot R$ .
- 7 In the **y** text field, type  $y_c - 2 \cdot R$ .



Now, create the cylinder.

#### *Cylinder 1 (cyl1)*



- 1 In the **Geometry** toolbar, click  **Cylinder**.
- 2 In the **Settings** window for **Cylinder**, locate the **Size and Shape** section.
- 3 In the **Radius** text field, type  $R$ .
- 4 In the **Height** text field, type  $H$ .
- 5 Locate the **Position** section. In the **x** text field, type  $x_c$ .
- 6 In the **y** text field, type  $y_c$ .
- 7 Locate the **Rotation Angle** section. In the **Rotation** text field, type  $45$ .
- 8 In the **Geometry** toolbar, click  **Build All**.

The following operations divide the flow domain into a number of subdomains. This way, a coarser mesh can be used far from the cylinder.

#### *Line Segment 1 (ls1)*

- 1 In the **Geometry** toolbar, click  **More Primitives** and choose **Line Segment**.
- 2 On the object **cyl1**, select Point 2 only.
- 3 In the **Settings** window for **Line Segment**, locate the **Endpoint** section.
- 4 Click to select the  **Activate Selection** toggle button for **End vertex**.
- 5 On the object **blk2**, select Point 5 only.

#### *Line Segment 2 (ls2)*

- 1 In the **Geometry** toolbar, click  **More Primitives** and choose **Line Segment**.
- 2 On the object **cyl1**, select Point 6 only.
- 3 In the **Settings** window for **Line Segment**, locate the **Endpoint** section.
- 4 Click to select the  **Activate Selection** toggle button for **End vertex**.
- 5 On the object **blk2**, select Point 7 only.





#### *Line Segment 3 (ls3)*

- 1 In the **Geometry** toolbar, click  **More Primitives** and choose **Line Segment**.
- 2 On the object **cyl1**, select Point 8 only.



- 3 In the **Settings** window for **Line Segment**, locate the **Endpoint** section.
- 4 Click to select the  **Activate Selection** toggle button for **End vertex**.
- 5 On the object **blk2**, select Point 8 only.

*Line Segment 4 (ls4)*

- 1 In the **Geometry** toolbar, click  **More Primitives** and choose **Line Segment**.
- 2 On the object **cyll**, select Point 4 only.
- 3 In the **Settings** window for **Line Segment**, locate the **Endpoint** section.
- 4 Click to select the  **Activate Selection** toggle button for **End vertex**.
- 5 On the object **blk2**, select Point 6 only.
- 6 Click  **Build All Objects**.
- 7 Click the  **Wireframe Rendering** button in the **Graphics** toolbar, and rotate the geometry to get a better view.

*Block 3 (blk3)*



- 1 In the **Geometry** toolbar, click  **Block**.
- 2 In the **Settings** window for **Block**, locate the **Size and Shape** section.
- 3 In the **Width** text field, type L.
- 4 In the **Depth** text field, type 2\*R.
- 5 In the **Height** text field, type H.



*Block 4 (blk4)*

- 1 Right-click **Block 3 (blk3)** and choose **Duplicate**.
- 2 In the **Settings** window for **Block**, locate the **Size and Shape** section.
- 3 In the **Depth** text field, type H-6\*R.
- 4 Locate the **Position** section. In the **y** text field, type 6\*R.
- 5 Click  **Build All Objects**.

Now, create the final computational domain with a hollow cylinder.

*Difference 1 (dif1)*

- 1 In the **Geometry** toolbar, click  **Booleans and Partitions** and choose **Difference**.
- 2 Select the objects **blk1** and **blk2** only.
- 3 In the **Settings** window for **Difference**, locate the **Difference** section.
- 4 Click to select the  **Activate Selection** toggle button for **Objects to subtract**.
- 5 Select the object **cyll** only.

- 6 In the **Geometry** toolbar, click  **Build All**.
- 7 Click the  **Wireframe Rendering** button in the **Graphics** toolbar. The geometry looks like the following image.
- 8 In the **Model Builder** window, click **Geometry 1**.

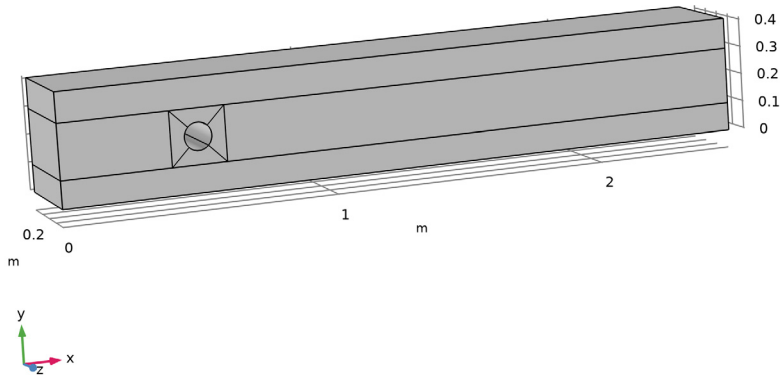

## DEFINITIONS



### Variables 1

- 1 In the **Home** toolbar, click  **Variables** and choose **Local Variables**.
- 2 In the **Settings** window for **Variables**, locate the **Variables** section.
- 3 In the table, enter the following settings:



Name	Expression	Unit	Description
Lct	$\text{intop1}(-\text{spf.T\_stressy}/(0.5*\text{spf.rho}*(U\_mean)^2*(2*R*H)))$		Lift coefficient
Ldt	$\text{intop1}(-\text{spf.T\_stressx}/(0.5*\text{spf.rho}*(U\_mean)^2*(2*R*H)))$		Drag coefficient
Lcmax	$\text{timemax}(0,8,Lct,'nointerp')$		Max lift coefficient
Ldmax	$\text{timemax}(0,8,Ldt,'nointerp')$		Max drag coefficient

Name	Expression	Unit	Description
Lcmin	timemin(0,8,Lct,'nointerp')		Min lift coefficient
Ldmin	timemin(0,8,Ldt,'nointerp')		Min drag coefficient
Lcsum	$\sqrt{\text{sum}((\text{at}(k*\text{dt},\text{Lct})-\text{liftref}(k*\text{dt}))^2,k,0,160)}$		Sum of differences, lift coefficient
relLc	$\text{Lcsum}/\sqrt{\text{sum}((\text{liftref}(k*\text{dt}))^2,k,0,160)}$		Relative error lift coefficient (L2)
Ldsum	$\sqrt{\text{sum}((\text{at}(k*\text{dt},\text{Ldt})-\text{dragref}(k*\text{dt}))^2,k,0,160)}$		Sum of differences, drag coefficient
relLd	$\text{Ldsum}/\sqrt{\text{sum}((\text{dragref}(k*\text{dt}))^2,k,0,160)}$		Relative error drag coefficient (L2)

#### Interpolation 1 (int1)

- 1 In the **Home** toolbar, click  **Functions** and choose **Local > Interpolation**.  
Load result files for the lift and drag coefficients to be used for verification.
- 2 In the **Settings** window for **Interpolation**, locate the **Definition** section.
- 3 From the **Data source** list, choose **File**.
- 4 Click  **Browse**.
- 5 Browse to the model's Application Libraries folder and double-click the file `cylinder_flow_3d_periodic_DragRef.txt`.
- 6 Click  **Import**.
- 7 In the **Function name** text field, type `dragref`.

#### Interpolation 2 (int2)

- 1 In the **Home** toolbar, click  **Functions** and choose **Local > Interpolation**.
- 2 In the **Settings** window for **Interpolation**, locate the **Definition** section.
- 3 Click  **Load from File**.
- 4 Browse to the model's Application Libraries folder and double-click the file `cylinder_flow_3d_periodic_LiftRef.txt`.

5 In the **Function name** text field, type `liftref`.

Define operators to verify the results using the imported data.

#### *Integration Surface*

- 1 In the **Definitions** toolbar, click  **Explicit**.
- 2 In the **Settings** window for **Explicit**, type `Integration Surface` in the **Label** text field.
- 3 Locate the **Input Entities** section. From the **Geometric entity level** list, choose **Boundary**.
- 4 Select Boundaries 21–24 only.

#### *Integration 1 (intop1)*

- 1 In the **Definitions** toolbar, click  **Nonlocal Couplings** and choose **Integration**.
- 2 In the **Settings** window for **Integration**, locate the **Source Selection** section.
- 3 From the **Geometric entity level** list, choose **Boundary**.
- 4 From the **Selection** list, choose **Integration Surface**.

#### *Verification Average Operator Domain*

- 1 In the **Definitions** toolbar, click  **Nonlocal Couplings** and choose **Average**.
- 2 In the **Settings** window for **Average**, type `Verification Average Operator Domain` in the **Label** text field.
- 3 In the **Operator name** text field, type `verificationaveop1`.
- 4 Locate the **Source Selection** section. From the **Selection** list, choose **All domains**.

#### *Verification Maximum Operator Domain*

- 1 In the **Definitions** toolbar, click  **Nonlocal Couplings** and choose **Maximum**.
- 2 In the **Settings** window for **Maximum**, type `Verification Maximum Operator Domain` in the **Label** text field.
- 3 Locate the **Source Selection** section. From the **Selection** list, choose **All domains**.

#### *Verification Minimum Operator Domain*

- 1 In the **Definitions** toolbar, click  **Nonlocal Couplings** and choose **Minimum**.
- 2 In the **Settings** window for **Minimum**, type `Verification Minimum Operator Domain` in the **Label** text field.
- 3 In the **Operator name** text field, type `verificationminop1`.
- 4 Locate the **Source Selection** section. From the **Selection** list, choose **All domains**.

#### *Verification Integration Operator Domain*

- 1 In the **Definitions** toolbar, click  **Nonlocal Couplings** and choose **Integration**.

- 2 In the **Settings** window for **Integration**, type Verification Integration Operator Domain in the **Label** text field.
- 3 In the **Operator name** text field, type verificationintop1.
- 4 Locate the **Source Selection** section. From the **Selection** list, choose **All domains**.

#### LAMINAR FLOW (SPF)

- 1 Click the  **Show More Options** button in the **Model Builder** toolbar.
- 2 In the **Show More Options** dialog, in the tree, select the checkbox for the node **Physics > Stabilization**.
- 3 Click **OK**.
- 4 In the **Model Builder** window, under **Component 1 (comp1)** click **Laminar Flow (spf)**.
- 5 In the **Settings** window for **Laminar Flow**, click to expand the **Consistent Stabilization** section.
- 6 Find the **Navier-Stokes equations** subsection. Clear the **Crosswind diffusion** checkbox.
- 7 Click to expand the **Discretization** section. From the **Discretization of fluids** list, choose **P2+P2**. P2+P2 is used because it is more conservative and more accurate than P2+P1 and P1+P1.

#### Fluid Properties 1

- 1 In the **Model Builder** window, under **Component 1 (comp1) > Laminar Flow (spf)** click **Fluid Properties 1**.
- 2 In the **Settings** window for **Fluid Properties**, locate the **Fluid Properties** section.
- 3 From the  $\rho$  list, choose **User defined**. In the associated text field, type rho.
- 4 From the  $\mu$  list, choose **User defined**. In the associated text field, type mu.

#### Inlet 1

- 1 In the **Physics** toolbar, click  **Boundaries** and choose **Inlet**.
- 2 Select Boundaries 1, 5, and 9 only.
- 3 In the **Settings** window for **Inlet**, locate the **Velocity** section.
- 4 In the  $U_0$  text field, type  $36*U\_mean*z*y*(H-y)*(H-z)/H^4*\sin(\pi*t/8[s])$ .

Here,  $1/[s]$  is used to make the input of  $\sin()$  dimensionless.

#### Outlet 1

- 1 In the **Physics** toolbar, click  **Boundaries** and choose **Outlet**.
- 2 Select Boundaries 31–33 only.

## MESH 1

Use advanced operations such as Map and Sweep to create a hexahedral mesh.

### *Mapped 1*

In the **Mesh** toolbar, click  **More Generators** and choose **Mapped**.

### *Size*

- 1 In the **Model Builder** window, click **Size**.
- 2 In the **Settings** window for **Size**, locate the **Element Size** section.
- 3 From the **Calibrate for** list, choose **Fluid dynamics**.
- 4 From the **Predefined** list, choose **Coarse**.

### *Mapped 1*

- 1 In the **Model Builder** window, click **Mapped 1**.
- 2 Select Boundaries 17, 18, 20, and 25 only.

### *Distribution 1*

- 1 Right-click **Mapped 1** and choose **Distribution**.
- 2 Select Edges 22, 24, 28, 32, 33, 36, 39, and 46 only.
- 3 In the **Settings** window for **Distribution**, click  **Build Selected**.

### *Distribution 2*

- 1 Right-click **Mapped 1** and choose **Distribution**.
- 2 Select Edges 23 and 27 only.
- 3 In the **Settings** window for **Distribution**, locate the **Distribution** section.
- 4 From the **Distribution type** list, choose **Predefined**.
- 5 In the **Element ratio** text field, type 2.
- 6 From the **Growth rate** list, choose **Exponential**.

### *Distribution 3*

- 1 Right-click **Mapped 1** and choose **Distribution**.
- 2 Select Edges 40 and 42 only.
- 3 In the **Settings** window for **Distribution**, locate the **Distribution** section.
- 4 From the **Distribution type** list, choose **Predefined**.
- 5 In the **Element ratio** text field, type 2.
- 6 From the **Growth rate** list, choose **Exponential**.
- 7 Click  **Build All**.

### *Mapped 2*

- 1 In the **Mesh** toolbar, click  **More Generators** and choose **Mapped**.
- 2 Select Boundaries 8 and 29 only.

### *Distribution 1*

- 1 Right-click **Mapped 2** and choose **Distribution**.
- 2 Select Edges 9 and 56 only.

### *Distribution 2*

- 1 In the **Model Builder** window, right-click **Mapped 2** and choose **Distribution**.
- 2 Select Edges 10 and 15 only.
- 3 In the **Settings** window for **Distribution**, locate the **Distribution** section.
- 4 From the **Distribution type** list, choose **Predefined**.
- 5 In the **Number of elements** text field, type 8.
- 6 In the **Element ratio** text field, type 3.
- 7 From the **Growth rate** list, choose **Exponential**.

### *Distribution 3*

- 1 Right-click **Mapped 2** and choose **Distribution**.
- 2 Select Edges 47 and 50 only.
- 3 In the **Settings** window for **Distribution**, locate the **Distribution** section.
- 4 From the **Distribution type** list, choose **Predefined**.
- 5 In the **Number of elements** text field, type 30.
- 6 In the **Element ratio** text field, type 6.
- 7 From the **Growth rate** list, choose **Exponential**.
- 8 Select the **Reverse direction** checkbox.

### *Mapped 3*

- 1 In the **Mesh** toolbar, click  **More Generators** and choose **Mapped**.
- 2 Select Boundaries 4 and 12 only.

### *Distribution 1*

- 1 Right-click **Mapped 3** and choose **Distribution**.
- 2 Select Edges 14 and 59 only.
- 3 In the **Settings** window for **Distribution**, locate the **Distribution** section.
- 4 From the **Distribution type** list, choose **Predefined**.

- 5 In the **Element ratio** text field, type 4.
- 6 From the **Growth rate** list, choose **Exponential**.



#### *Distribution 2*

- 1 In the **Model Builder** window, right-click **Mapped 3** and choose **Distribution**.
- 2 Select Edges 4 and 53 only.
- 3 In the **Settings** window for **Distribution**, locate the **Distribution** section.
- 4 From the **Distribution type** list, choose **Predefined**.
- 5 In the **Element ratio** text field, type 4.
- 6 From the **Growth rate** list, choose **Exponential**.
- 7 Select the **Reverse direction** checkbox.

#### *Distribution 3*

- 1 Right-click **Mapped 3** and choose **Distribution**.
- 2 Select Edges 5 and 18 only.
- 3 In the **Settings** window for **Distribution**, locate the **Distribution** section.
- 4 From the **Distribution type** list, choose **Predefined**.
- 5 In the **Number of elements** text field, type 43.
- 6 In the **Element ratio** text field, type 1.6.
- 7 From the **Growth rate** list, choose **Exponential**.

#### *Swept 1*

- 1 In the **Mesh** toolbar, click  **Swept**.
- 2 In the **Settings** window for **Swept**, click to expand the **Source Faces** section.
- 3 Select Boundaries 4, 8, 12, 17, 18, 20, 25, and 29 only.
- 4 Click to expand the **Destination Faces** section. Click to clear the  **Activate Selection** toggle button.
- 5 Select Boundaries 3, 7, 11, 16, and 28 only.

#### *Distribution 1*

- 1 Right-click **Swept 1** and choose **Distribution**.
- 2 In the **Settings** window for **Distribution**, locate the **Distribution** section.
- 3 From the **Distribution type** list, choose **Predefined**.
- 4 In the **Number of elements** text field, type 10.
- 5 In the **Element ratio** text field, type 4.



- 6 From the **Growth rate** list, choose **Exponential**.
- 7 Select the **Symmetric distribution** checkbox.
- 8 Click  **Build All**.

The mesh in [Figure 2](#) is now generated.



## STUDY I

### *Step 1: Time Dependent*

- 1 In the **Model Builder** window, under **Study I** click **Step 1: Time Dependent**.
- 2 In the **Settings** window for **Time Dependent**, locate the **Study Settings** section.
- 3 In the **Output times** text field, type range (0, 0.05, 8).
- 4 From the **Tolerance** list, choose **User controlled**.
- 5 In the **Relative tolerance** text field, type 0.001.

### *Solution 1 (sol1)*

Choose the generalized alpha method for the time stepping. It has less damping than the BDF.

- 1 In the **Study** toolbar, click  **Show Default Solver**.
- 2 In the **Model Builder** window, expand the **Solution 1 (sol1)** node.
- 3 In the **Model Builder** window, under **Study I > Solver Configurations > Solution 1 (sol1)** click **Time-Dependent Solver 1**.
- 4 In the **Settings** window for **Time-Dependent Solver**, click to expand the **Time Stepping** section.
- 5 From the **Method** list, choose **Generalized alpha**.
- 6 Select the **Initial step** checkbox. In the associated text field, type 0.01.
- 7 From the **Maximum step constraint** list, choose **Constant**.
- 8 In the **Study** toolbar, click  **Compute**.

Evaluate the drag and lift coefficients.

## RESULTS

### *Surface 2*

- 1 In the **Results** toolbar, click  **More Datasets** and choose **Surface**.
- 2 Select Boundaries 21–24 only.

### Integral I

- 1 In the **Results** toolbar, click  **More Datasets** and choose **Evaluation > Integral**.
- 2 In the **Settings** window for **Integral**, locate the **Data** section.
- 3 From the **Dataset** list, choose **Surface 2**.

### Point Evaluation I

- 1 In the **Results** toolbar, click  **Point Evaluation**.
- 2 In the **Settings** window for **Point Evaluation**, locate the **Data** section.
- 3 From the **Dataset** list, choose **Integral I**.
- 4 Locate the **Expressions** section. In the table, enter the following settings:

Expression	Unit	Description
$-\text{spf.T\_stressy}/(0.5*\text{spf.rho}*(\text{U\_mean})^2*(2*\text{R}*H))$	1	Lift coefficient
$-\text{spf.T\_stressx}/(0.5*\text{spf.rho}*(\text{U\_mean})^2*(2*\text{R}*H))$	1	Drag coefficient

- 5 Click  **Evaluate**.

### TABLE I

- 1 Go to the **Table I** window.
- 2 Click the **Table Graph** button in the window toolbar.

### TABLE I

- 1 Go to the **Table I** window.
- 2 Click the **Table Graph** button in the window toolbar.  
Plot the lift coefficient versus time as shown in [Figure 4](#).
- 3 In the **Settings** window for **Table Graph**, locate the **Data** section.
- 4 From the **Plot columns** list, choose **Manual**.
- 5 In the **Columns** list, select **Lift coefficient (I), Integral I**.

## RESULTS

### Lift coefficient

- 1 In the **Model Builder** window, under **Results** click **ID Plot Group 3**.
- 2 In the **Settings** window for **ID Plot Group**, type Lift coefficient in the **Label** text field.
- 3 Locate the **Plot Settings** section.

4 Select the **y-axis label** checkbox. In the associated text field, type  $c_L$ .

#### *Drag coefficient*

Plot the drag coefficient versus time as shown in [Figure 5](#).

- 1 Right-click **Lift coefficient** and choose **Duplicate**.
- 2 In the **Settings** window for **ID Plot Group**, type **Drag coefficient** in the **Label** text field.
- 3 Locate the **Plot Settings** section. In the **y-axis label** text field, type  $c_D$ .



#### *Table Graph 1*

- 1 In the **Model Builder** window, expand the **Drag coefficient** node, then click **Table Graph 1**.
- 2 In the **Settings** window for **Table Graph**, locate the **Data** section.
- 3 In the **Columns** list, select **Drag coefficient (1)**, **Integral 1**.
- 4 In the **Drag coefficient** toolbar, click  **Plot**.



#### *Point Evaluation 1*

Evaluate the maximum and minimum of the coefficients.

#### *Point Evaluation 2*

- 1 In the **Model Builder** window, under **Results > Derived Values** right-click **Point Evaluation 1** and choose **Duplicate**.
- 2 In the **Settings** window for **Point Evaluation**, locate the **Data Series Operation** section.
- 3 From the **Transformation** list, choose **Maximum**.
- 4 Click  next to  **Evaluate**, then choose **New Table**.

#### *Point Evaluation 3*

- 1 Right-click **Point Evaluation 2** and choose **Duplicate**.
- 2 In the **Settings** window for **Point Evaluation**, locate the **Expressions** section.
- 3 Click to select row number 2 in the table.
- 4 Right-click and choose **Delete**.
- 5 Locate the **Data Series Operation** section. From the **Transformation** list, choose **Minimum**.
- 6 Click  next to  **Evaluate**, then choose **Table 2 - Point Evaluation 2**.

#### *Surface 3*

- 1 In the **Results** toolbar, click  **More Datasets** and choose **Surface**.
- 2 Select Boundaries 2, 13, and 21–24 only.

Now, visualize the velocity field as shown in [Figure 3](#).

### *Velocity (spf)*

- 1 In the **Model Builder** window, under **Results** click **Velocity (spf)**.
- 2 In the **Settings** window for **3D Plot Group**, locate the **Color Legend** section.
- 3 Clear the **Show legends** checkbox.
- 4 Locate the **Plot Settings** section. Clear the **Plot dataset edges** checkbox.
- 5 Locate the **Data** section. From the **Time (s)** list, choose **7.95**. Since the inlet velocity vanishes at the final time step, the solution at  $t=7.95s$  is chosen for a better visualization of the streamlines.

### *Slice*

Create a slice in the middle of the computational domain, parallel to the  $xy$  – plane to see the flow pattern more clearly.

- 1 In the **Model Builder** window, expand the **Velocity (spf)** node, then click **Slice**.
- 2 In the **Settings** window for **Slice**, locate the **Plane Data** section.
- 3 From the **Plane** list, choose **xy-planes**.
- 4 In the **Planes** text field, type 1.
- 5 Locate the **Coloring and Style** section. From the **Color table** list, choose **JupiterAuroraBorealis**.

### *Deformation 1*

Shift the slice back to the wall to get a better view.

- 1 Right-click **Slice** and choose **Deformation**.
- 2 In the **Settings** window for **Deformation**, locate the **Expression** section.
- 3 In the **z-component** text field, type -0.205.
- 4 Locate the **Scale** section.
- 5 Select the **Scale factor** checkbox. In the associated text field, type 1.

### *Streamline 1*

Create and add arrows to the streamlines.

- 1 In the **Model Builder** window, right-click **Velocity (spf)** and choose **Streamline**.
- 2 In the **Settings** window for **Streamline**, locate the **Streamline Positioning** section.
- 3 In the **Number** text field, type 10.
- 4 Select Boundaries 1, 5, and 9 only.
- 5 Locate the **Coloring and Style** section. Find the **Line style** subsection. From the **Type** list, choose **Tube**.

- 6 Select the **Radius scale factor** checkbox. In the associated text field, type 0.003.
- 7 Find the **Point style** subsection. From the **Type** list, choose **Arrow**.
- 8 From the **Color** list, choose **Custom**.
- 9 On Windows, click the colored bar underneath, or — if you are running the cross-platform desktop — the **Color** button.
- 10 Click **Define custom colors**.
- 11 Set the RGB values to 71, 145, and 199, respectively.
- 12 Click **Add to custom colors**.
- 13 Click **Show color palette only** or **OK** on the cross-platform desktop.

#### *Surface 1*

- 1 Right-click **Velocity (spf)** and choose **Surface**.
- 2 In the **Settings** window for **Surface**, locate the **Data** section.
- 3 From the **Dataset** list, choose **Surface 3**.
- 4 Locate the **Expression** section. In the **Expression** text field, type 1.
- 5 Locate the **Coloring and Style** section. From the **Coloring** list, choose **Uniform**.
- 6 From the **Color** list, choose **Gray**.

#### *Evaluation Group 1*

- 1 In the **Results** toolbar, click  **Evaluation Group**.
- 2 In the **Settings** window for **Evaluation Group**, locate the **Data** section.
- 3 From the **Time selection** list, choose **Last**.

#### *Global Evaluation 1*

- 1 Right-click **Evaluation Group 1** and choose **Global Evaluation**.
- 2 In the **Settings** window for **Global Evaluation**, locate the **Expressions** section.
- 3 In the table, enter the following settings:

<b>Expression</b>	<b>Unit</b>	<b>Description</b>
Lcmax	1	Max lift coefficient
Lcmin	1	Min lift coefficient
Ldmax	1	Max drag coefficient
relLc	1	Relative error lift coefficient (L2)
relLd	1	Relative error drag coefficient (L2)

- 4 In the **Evaluation Group 1** toolbar, click  **Evaluate**.

